

Validation against current approaches

Virtual Upscaling

Version	Date	Person	Changes
0.1	30.06.2018	Haritz Vallejo, Miguel Seco	

Table of contents

Table of contents	2
Abbreviations/ terms	4
1 Introduction	5
2 Background	5
3 Objectives.....	6
4 Description of the task.....	6
5 Validation of the simulation procedure	6
5.1 Procedure	6
5.2 Validation models.....	7
5.3 Validation model 1	10
5.3.1 Comparison of resolution times	10
5.3.2 Comparison of numerical results.....	10
5.3.2.1 Thermal results.....	11
5.3.2.2 Mechanical results	12
5.4 Validation model 2	13
5.4.1 Comparison of resolution times	13
5.4.2 Comparison of numerical results.....	13
5.4.2.1 Thermal results.....	14
5.4.2.2 Mechanical results	15
6 Conclusions	15

Abbreviations/ terms

AM	Additive Manufacturing
FDM	Finite Difference Method
FE	Finite Element
FEA	Finite Element Analysis
FEM	Finite Element Method
KIC	Knowledge and Innovation Communities
MF	Modelling Factory is an infrastructure KAVA project of the EIT Raw Materials KIC, results an integration platform
VU	Project based on analyzing upscaling cases from KIC partners participating in MF
WAAM	Wire and Arc Additive Manufacturing

1 Introduction

The Virtual Upscaling (VU) project is based on analysing upscaling cases from KIC (Knowledge and Innovation Communities) partners participating in Modelling Factory (MF) that is an infrastructure KAVA project of the EIT Raw Materials KIC. Based on the selected cases we will define a sequence of methods, tools and interface data models (ontologies) in order to find commonly defined practices for virtual upscaling process. For this study, methods, tools, ontologies and transformations will be made available through Modelling Factory.

Two case studies are planned to be analysed within WP3 of the Virtual Upscaling project to extract requirements for the generic virtual upscaling tools developed in WP4. This document focuses on Task 3.2, the second case study, related to Additive Manufacturing (AM) and led by Tecnia, and presents the validation phase of the efficient simulation procedure developed.

2 Background

In Additive Manufacturing (AM) processes, a 3D component is built up by sequentially adding layers of material and thus has several benefits over the subtraction technologies, in terms of effectiveness and in saving resources. Moreover, it can enable the manufacturing of more competitive products due to its capability of producing more complex and cheaper parts. There are numerous metal Additive Manufacturing types, depending on the motion system, the heat source used and the way the material is deposited. Task 3.2 of the Virtual Upscaling project is focused on Wire and Arc Additive Manufacturing (WAAM).

Distortions and residual stresses are the two major problems that need to be handled to produce fit for purpose components by WAAM. Process simulation becomes therefore cornerstone to overtake these potential problems, by predicting the manufacturing and optimizing the process parameters, so that competitive and quality components are achieved.

These kinds of simulations are however highly non-linear and very expensive from a computational cost point of view. Real engineering purposes require much more efficient numerical modelling capabilities and thus, much research is being done to achieve computationally efficient approaches able to predict accurate thermo-mechanical results in practical time.

Within Task 3.2 of the Virtual Upscaling project, the development and validation of a novel simulation procedure that combines the use of Finite Difference and Finite Element Methods (FDM and FEM, respectively) for the efficient resolution of simulations related to Wire and Arc Additive Manufacturing processes is intended. Detailed information about this novel procedure can be found in Deliverable D3.2.1.

3 Objectives

The main objectives of the work conducted by Tecnia within Virtual Upscaling project are:

- Development and validation of a simulation procedure able to efficiently simulate Wire and Arc Additive Manufacturing processes
- Development of a simulation tool that follows this procedure
- Assess the accuracy of the numerical results and the reduction of computational cost
- Extract requirements for the Modelling Factory with this development

4 Description of the task

Task 3.2 of Virtual Upscaling project aim at extracting requirement for the Modelling Factory with a use case in which a computational method to efficiently simulate WAAM processes is planned to be developed. Work will be carried out using following steps:

1. Review of existing approaches already tested in literature to reduce computational cost in thermo-mechanical calculations for additive manufacturing processes.
2. Creation of input/output data card in terms of process, computation and optimization required inputs.
3. Construction of the thermo-mechanical model capable of predicting information necessary for the user (phase distributions, residual stresses etc.).
4. Simulation of the developed, cost effective, models and comparison with results from current strategies.
5. Standardize the best models and define the virtual upscaling method in collaboration with WP4.

5 Validation of the simulation procedure

5.1 Procedure

To validate both the novel simulation procedure developed and the simulation structure that follows this procedure, their operative and corresponding results are compared to the ones from a common WAAM Finite Element Analysis conducted through MSC-Marc. At the same time, the resolution time saving is checked.

To ensure the validation, two validation WAAM processes are simulated.

5.2 Validation models

Geometries and dimensions of the validation models are presented below. As shown, the manufacturing process of a single vertical wall is intended to be simulated through the first validation model. In the second case, a more complex doubly crossed vertical walls is numerically assessed.

The manufacturing process of both parts is divided into three main steps:

1. Material addition
2. Cooling down
3. Unclamping

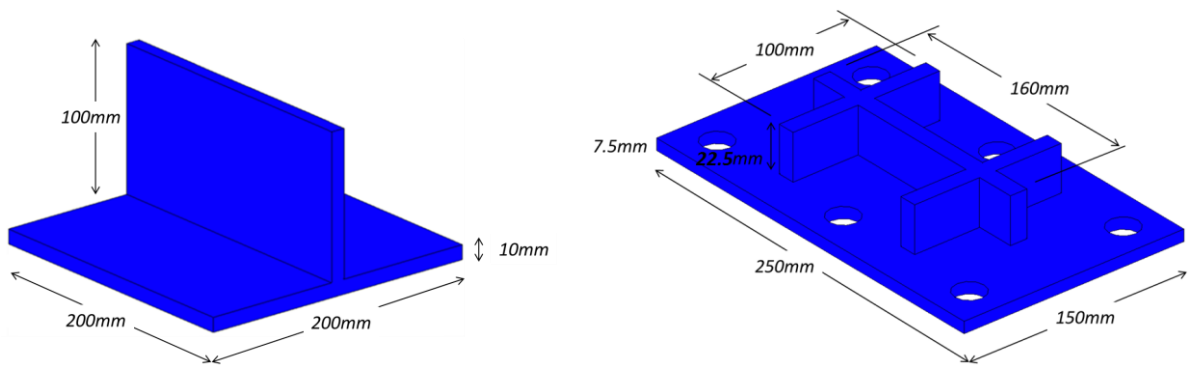

Figure 1 Main dimensions of validation models

The three-dimensional Finite Element Meshes built for each model are presented below. Validation Model 1 includes 2480 linear hexahedral elements and 4756 nodes, while the second mesh is formed by 3266 linear hexahedral elements and 4790 nodes.

Although this meshes might be relatively coarse considering non-linearities that this kind of simulation entails, it is decided to complete the validation this way to avoid unpractical resolution times.

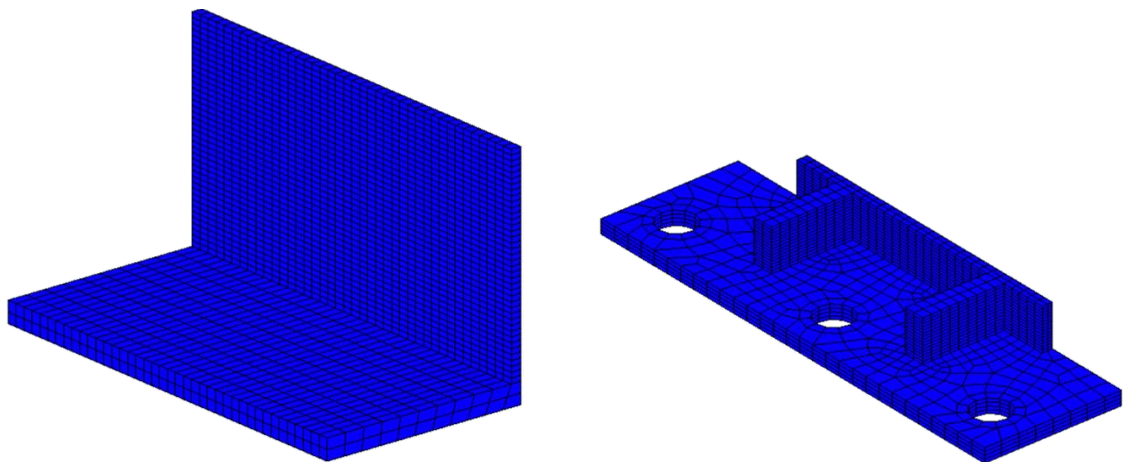

Figure 2 Meshes corresponding to validation models

Considered process parameters for each case are presented in Table 1.

<i>Process parameter</i>	<i>Validation Model 1</i>	<i>Validation Model 2</i>
Deposition layers: <ul style="list-style-type: none"> • Number • Height [mm] • Width [mm] 	20 5 10	15 1.5 11.25
Thermal flux: <ul style="list-style-type: none"> • Power [W] • Width [mm] • Depth [mm] • Forward length [mm] • Rear length [mm] 	3000 6.1 4.6 5 9.75	1000 6.1 4.6 5 9.75
Waiting time [s]	50	30
Deposition velocity [mm/s]	4	4 (main wall) ÷ 4.44375 (crosses)
Cooling time [s]	10000	10000

Table 1 Process parameters for the validation simulations

Validation models are assumed to be made of Ti6Al4V. The temperature-dependent material properties assumed are presented below. Material density is 4540kg/m³.

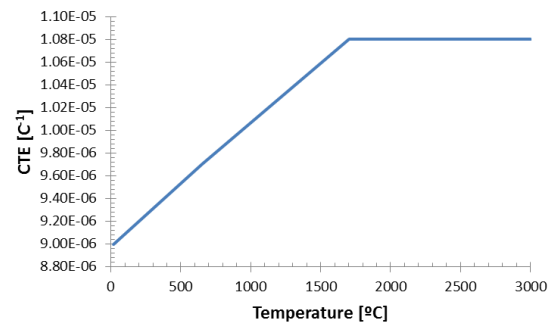
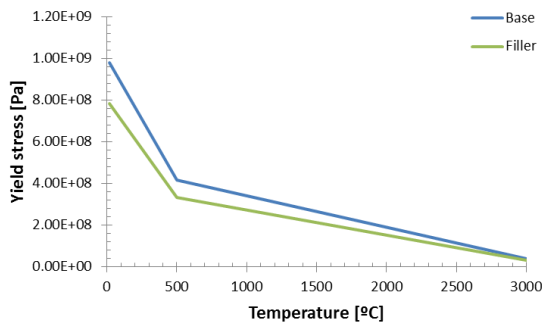
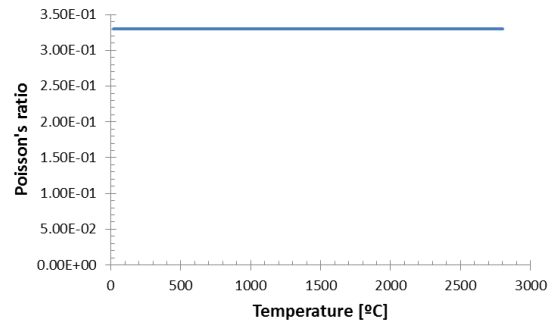
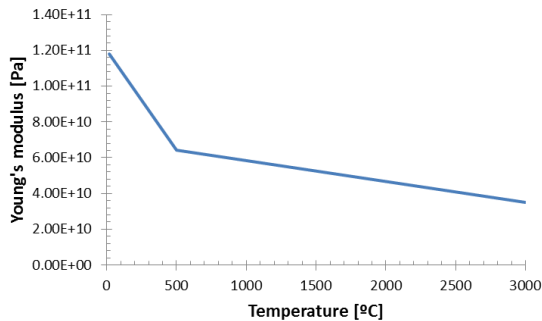

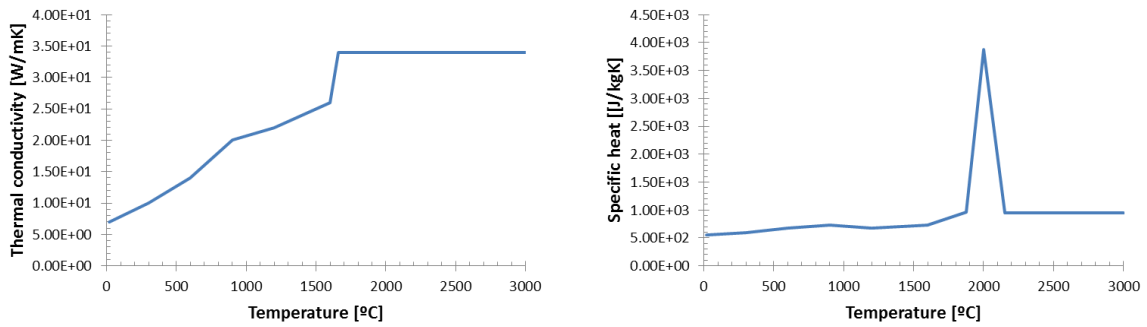

Figure 3 Material properties for validation simulations

Regarding thermal and mechanical boundary conditions, considered conditions are described in the following table.

<i>Boundary and initial conditions</i>	<i>Simulation model 1</i>	<i>Simulation model 2</i>
Film coefficient [W/m ² K]	5	5
Surface emissivity	1	0.3
Ambient temperature [°C]	20	20
Clamping condition	Substrate bottom totally fixed during material addition and cooling down stage. Totally free (just a trivial constrain to avoid solid body movement) for the unclamping process.	6 screws during material addition and cooling down stage. Totally free (just a trivial constrain to avoid solid body movement) for the unclamping process.
Initial temperature [°C]	500	20

Table 2 Boundary conditions for the validation simulations

5.3 Validation model 1

Both the resolution times and the numerical results corresponding to the first validation simulation and the ones obtained through a common fully-coupled thermo-mechanical Finite Element Analysis with MSC-Marc are compared below.

5.3.1 Comparison of resolution times

As shown in Figure 4, the resolution time is significantly reduced in case of solving the problem through the novel procedure proposed. For this first validation case a decrease of 70% is obtained in comparison with the common FEA.

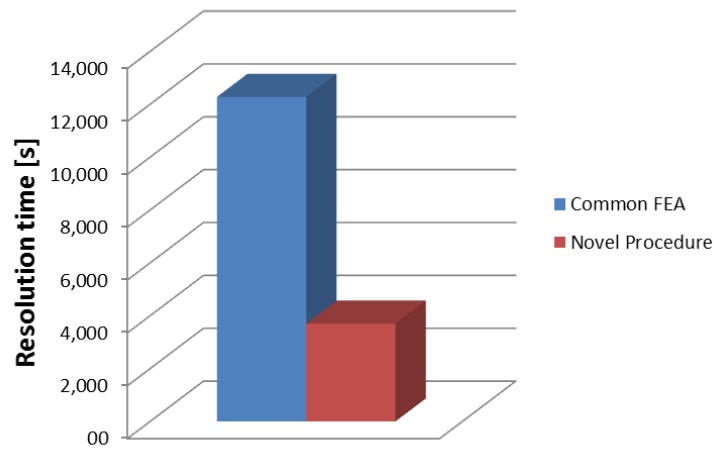

Figure 4 Comparison of resolution times

5.3.2 Comparison of numerical results

To check the correct operative of the novel procedure, the temperature evolutions of three virtual thermocouples (T1, T2 and T3) and the final vertical distortions along two paths (P1 and P2) are checked, as shown in the figures below.

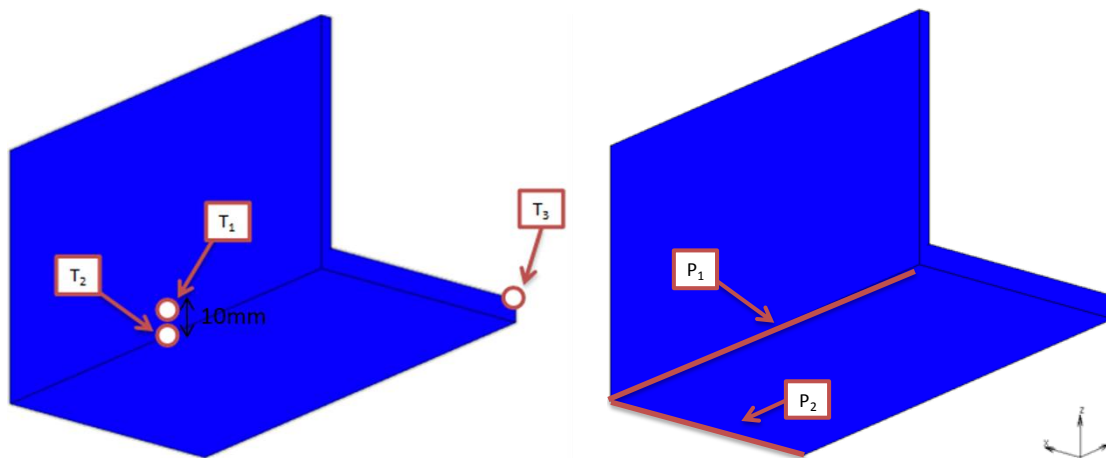

Figure 5 Virtual thermocouples (left) and paths (right) used for results correlation

5.3.2.1 Thermal results

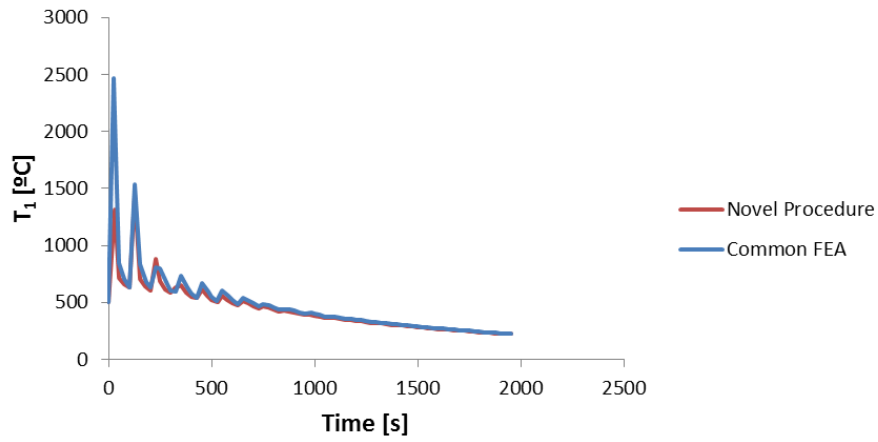

Figure 6 Temperature evolution at T1 according to the novel procedure and the common FEA

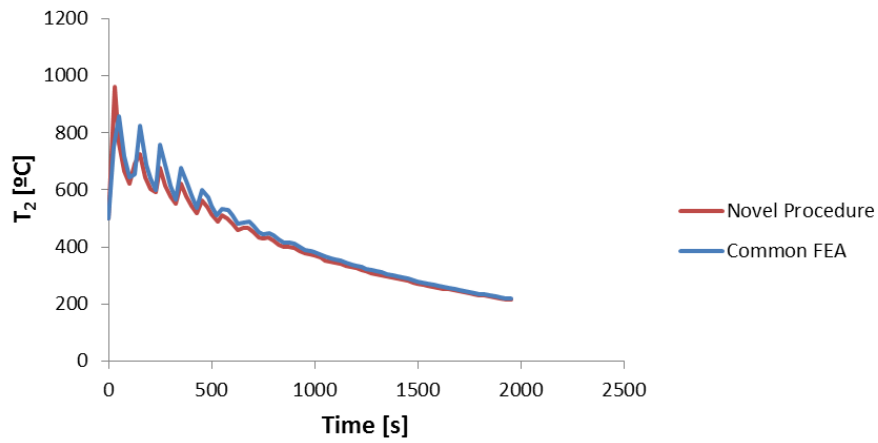

Figure 7 Temperature evolution at T2 according to the novel procedure and the common FEA

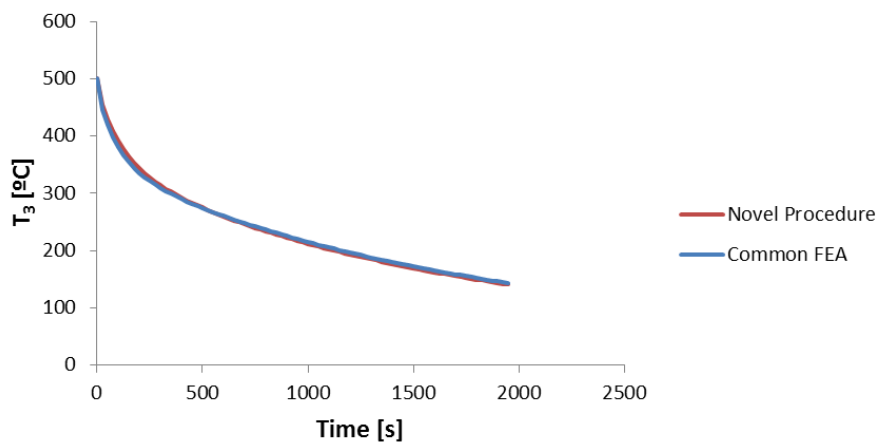

Figure 8 Temperature evolution at T3 according to the novel procedure and the common FEA

According to these numerical results, following average deviations are calculated for each virtual thermocouple considering the whole manufacturing process.

<i>Thermocouple</i>	<i>Average deviation [%]</i>
1	-3.01
2	-2.55
3	0.64

Table 3 Average deviation corresponding to the thermal results of Validation Model 1

5.3.2.2 Mechanical results

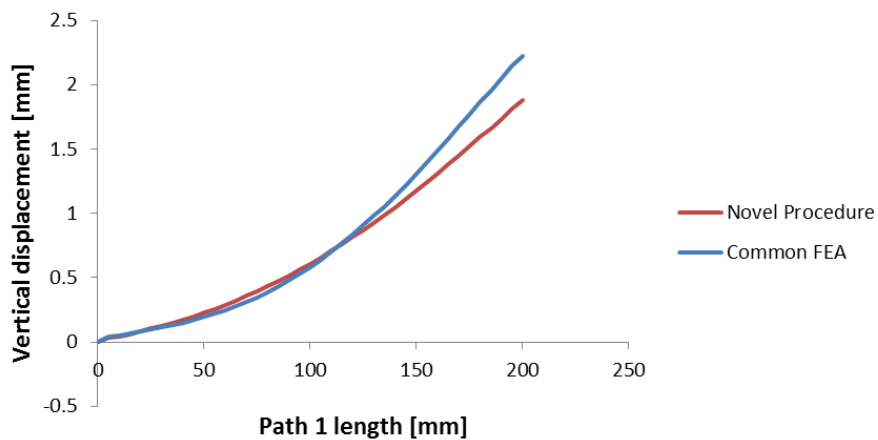

Figure 9 Final vertical distortions along P1 at the end of the process according to the novel procedure and the common FEA

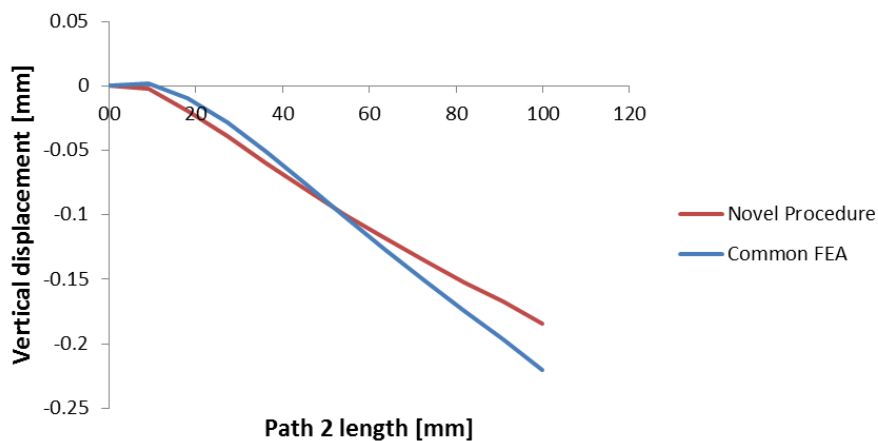

Figure 10 Final distortions along P2 at the end of the process according to the novel procedure and the common FEA

According to these numerical results, average deviations of 0.91% and 10.10% are calculated for Path 1 and Path 2, respectively.

5.4 Validation model 2

Both the resolution times and the numerical results corresponding to the second validation simulation and the ones obtained through a common fully-coupled thermo-mechanical Finite Element Analysis with MSC-Marc are compared below.

5.4.1 Comparison of resolution times

As shown in Figure 4, the resolution time is significantly reduced in case of solving the problem through the novel procedure proposed. For this first validation case a decrease of 75% is obtained in comparison with the common FEA.

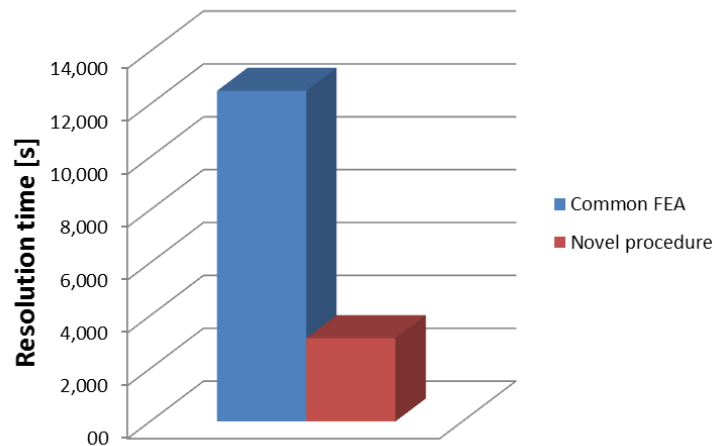

Figure 11 Comparison of resolution times

5.4.2 Comparison of numerical results

To check the correct operative of the novel procedure, the temperature evolutions of three virtual thermocouples (T1, T2 and T3) and the final vertical distortions along one paths (P1) are checked, as shown in the figures below.

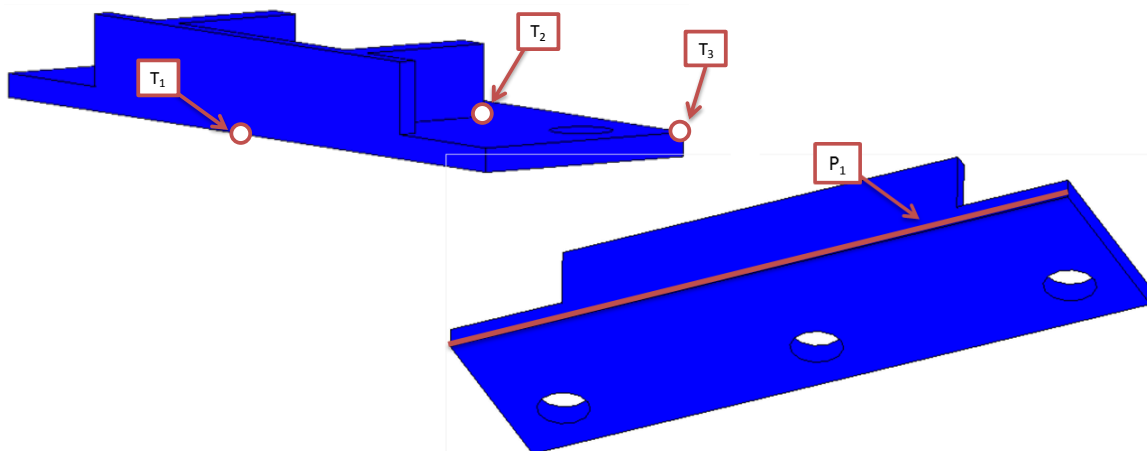

Figure 12 Virtual thermocouples (left) and path (right) used for results correlation

5.4.2.1 Thermal results

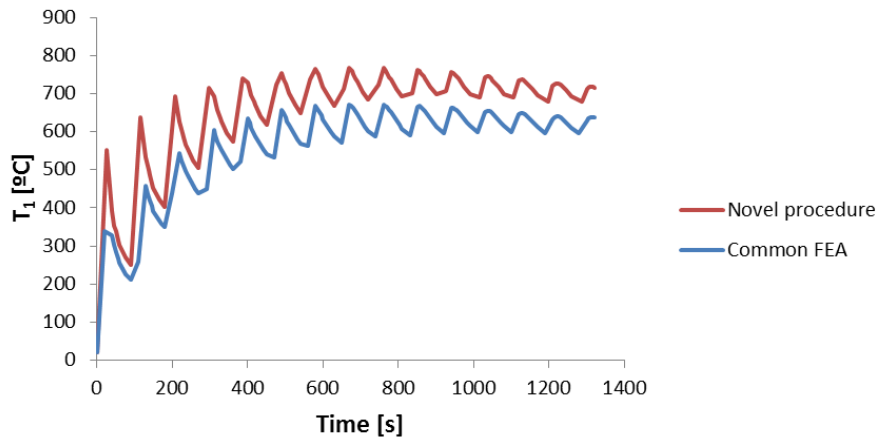

Figure 13 Temperature evolution at T1 according to the novel procedure and the common FEA

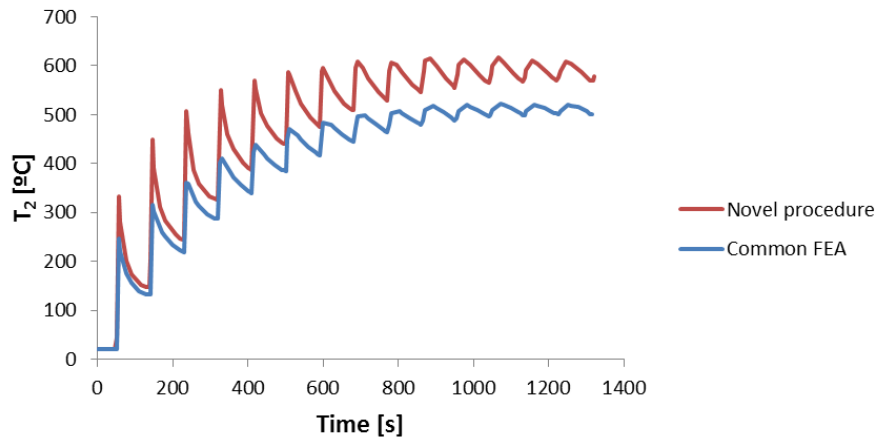

Figure 14 Temperature evolution at T2 according to the novel procedure and the common FEA

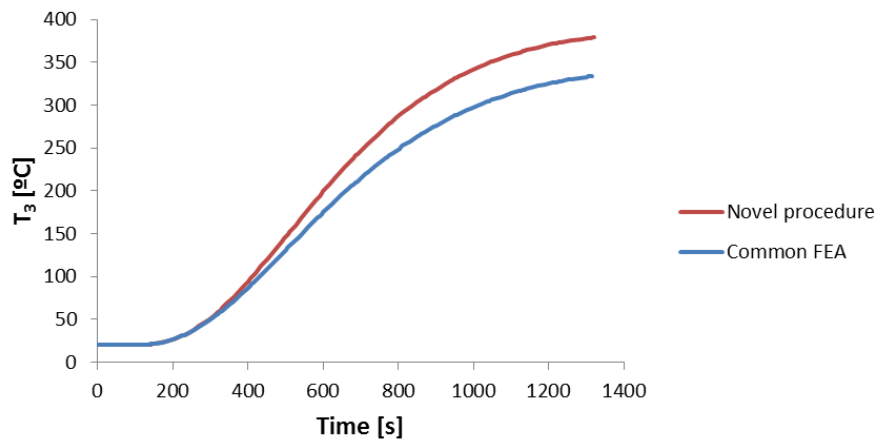

Figure 15 Temperature evolution at T3 according to the novel procedure and the common FEA

According to these numerical results, following average deviations are calculated for each virtual thermocouple considering the whole manufacturing process.

<i>Thermocouple</i>	<i>Average deviation [%]</i>
1	4.83
2	5.47
3	2.78

Table 4 Average deviation corresponding to the thermal results of Validation Model 2

5.4.2.2 Mechanical results

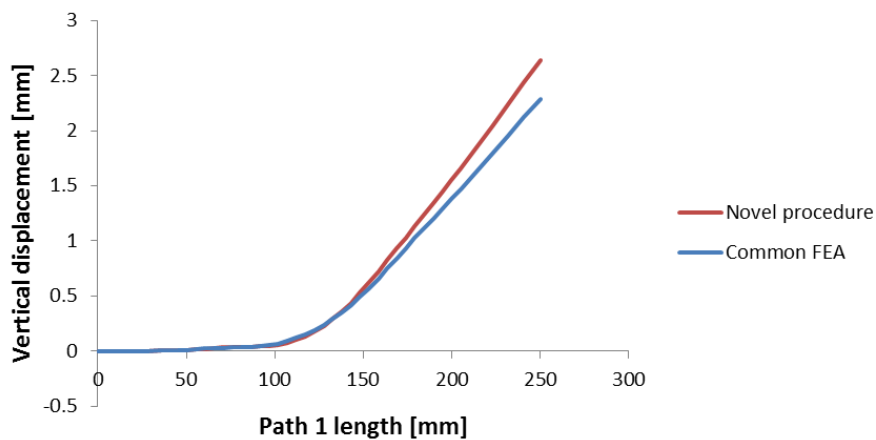

Figure 16 Final distortions along P1 at the end of the process according to the novel procedure and the common FEA

According to these numerical results, an average deviation of -7.05% is calculated.

6 Conclusions

The validation stage described in the present document indicates that the resolution times can considerably be reduced thanks to the procedure proposed while keeping accurate enough numerical results of both thermal and mechanical phenomena.

Therefore, it is concluded that the simulation procedure developed within the Virtual Upscaling project is able to efficiently simulate Wire and Arc Additive Manufacturing processes.